



# Renovation of Buildings using Steel Technologies (ROBUST)

RFCS Project RFSR-CT-2007-0043

## WP 1.3 Strategies to improve air-tightness in building renovation

Date: 2009  
Author: Mark Lawson

## STRATEGIES TO IMPROVE AIR-TIGHTNESS IN BUILDING RENOVATION

The strategy to improve the air-tightness in renovation of existing buildings depends on:

- the building type and form e.g. cellular building or large enclosure.
- the materials used e.g. concrete, block-work or metallic sheets.
- the element of construction e.g. wall or roof.
- the new cladding or roofing system that is added.
- the possibility of intervention with the building during renovation work.

These strategies are explained with respect to typical wall and roof constructions, as follows:

### 1 Existing wall constructions using concrete or block-work.

In existing concrete panel or block-work construction, the poor air-tightness of the façade is largely due to the air leakage through the joints between the panels or blocks and around windows. In renovation of these types of buildings, new insulation is placed externally to improve the thermal performance but the air leakage has to be reduced by additional measures. Furthermore, the air barrier that reduces air leakage should be positioned so as not to cause the risk of condensation. An additional vapour barrier is often required to eliminate risk of interstitial condensation, and this may also act as an air barrier.

Various forms of over-cladding may be considered.

Type 1: Drained and ventilated systems (normally considered as 'rain screens') achieve pressure equalisation in the cavity space behind the new cladding, and the cavity space ensures that any moisture that enters behind the rain screen is drained.

Type 2: Drained and ventilated systems may also be combined with an additional sheathing board external to the existing building, which provides an additional protective layer on which the vapour barrier may be installed.

Type 3: Face sealed cladding systems prevent any moisture ingress, provided details around windows etc are properly sealed. Composite panels (sandwich panels) can be installed to act as face sealed cladding by suitable details around windows.

Type 4: Drained but unventilated systems prevent air movement in the cavity space, but allow for drainage of any small amount of water that may enter behind the new cladding. These hybrid systems rely on minimal air movement behind the new cladding.

The relative positions of the various barriers are indicated in the following figures for these types of over-cladding. These include:

- A Rain barrier
- B Wind barrier
- C Air barrier (for air tightness)

D Vapour barrier

Type 1: In drained and ventilated systems, the vapour barrier must be located on the 'warm' face of the building. Also, because the existing cladding may contain moisture, it is not feasible to locate the vapour barrier externally. Therefore, the only sensible location is to place the vapour and air barrier internally to the existing wall. The vapour barrier also reduces air leakage. It is also necessary to introduce a breather membrane to act as a wind barrier external to the insulation.

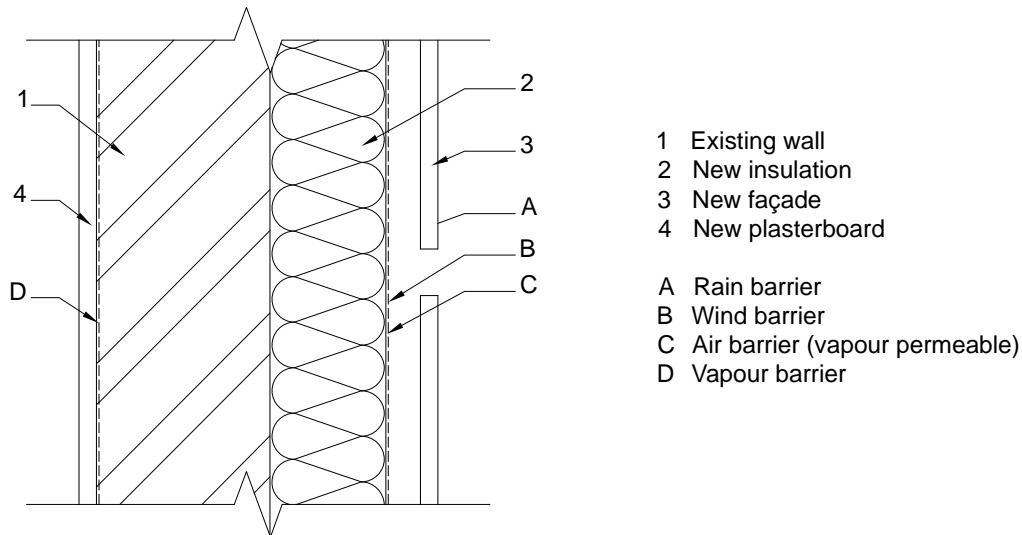

Type 1: Ventilated façade (rainscreen)

Scale 1:5

Type 2: In this modified drained and ventilated system, an external sheathing board is attached, which also contains a vapour barrier. The new insulation is then attached to the sheathing board. Some modest ventilation to the existing façade is permitted. This is clearly more complex than Type 1, but means that no intervention within the building is required.

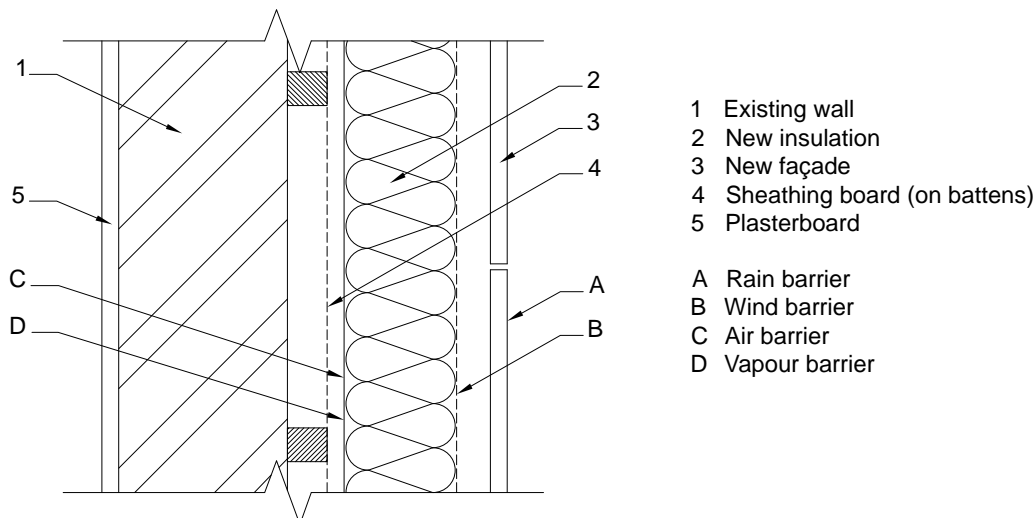

Type 2: Drained and ventilated façade (with sheathing board)

Scale 1:5

Type 3: In this face sealed system, the external composite panel provides all major weather resisting, insulation and air –tightness functions. The rear face of the panel also acts as a vapour barrier. However, the joints between the panels and with the insulated flashings around the windows become crucial to the thermal performance of the new cladding system..

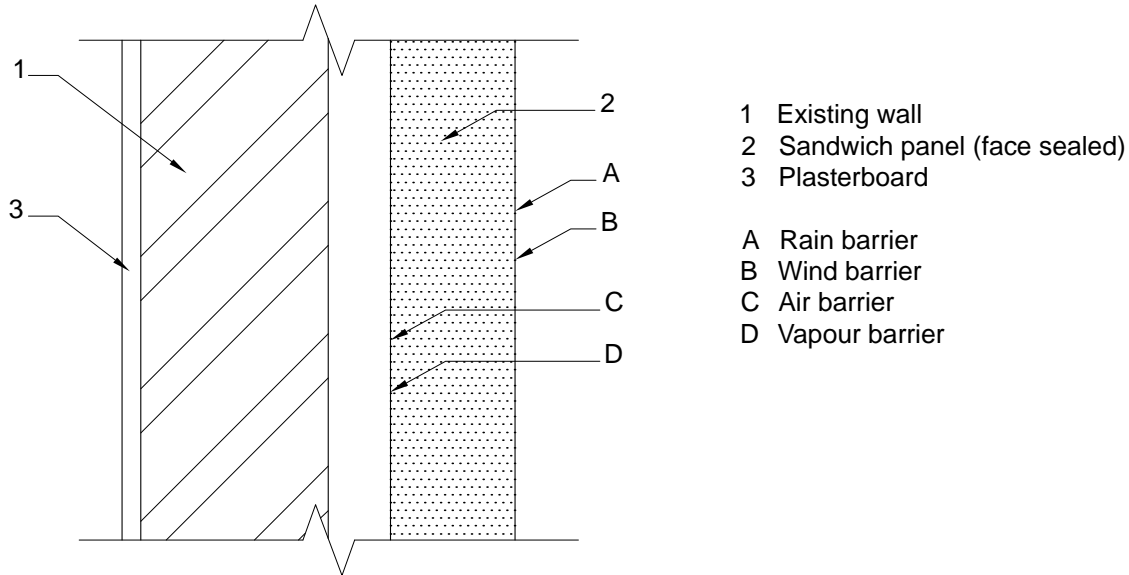

Type 3: Fully sealed sandwich (composite) panel

Scale 1:5

Type 4: In this hybrid drained but unventilated system using composite panels, the cavity space allows for drainage of any water that condenses on the metallic elements. Both the vapour barrier and air barrier have to be placed internally to the existing cladding. The drainage of the cavity prevents build-up of any moisture that may penetrate around the windows etc.

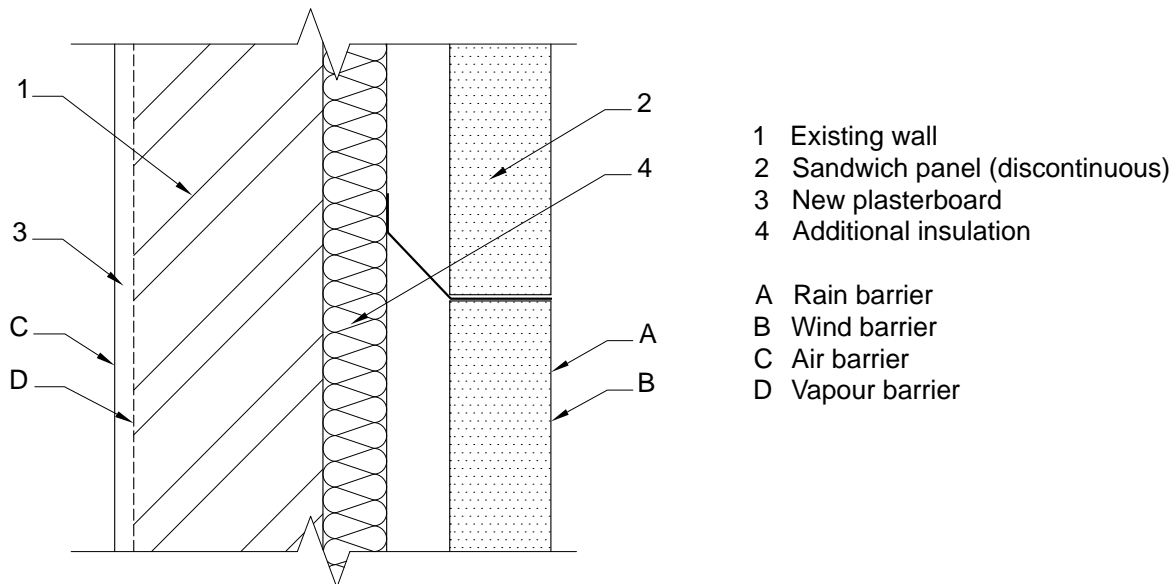

Type 4: Drained unventilated sandwich panel

Scale 1:5

Type 5: It is also possible to combine the above systems with insulation placed internally to the existing wall, often in the form of insulated plasterboard. In this case, the vapour barrier and air barriers can be installed internally with the insulated plasterboard.

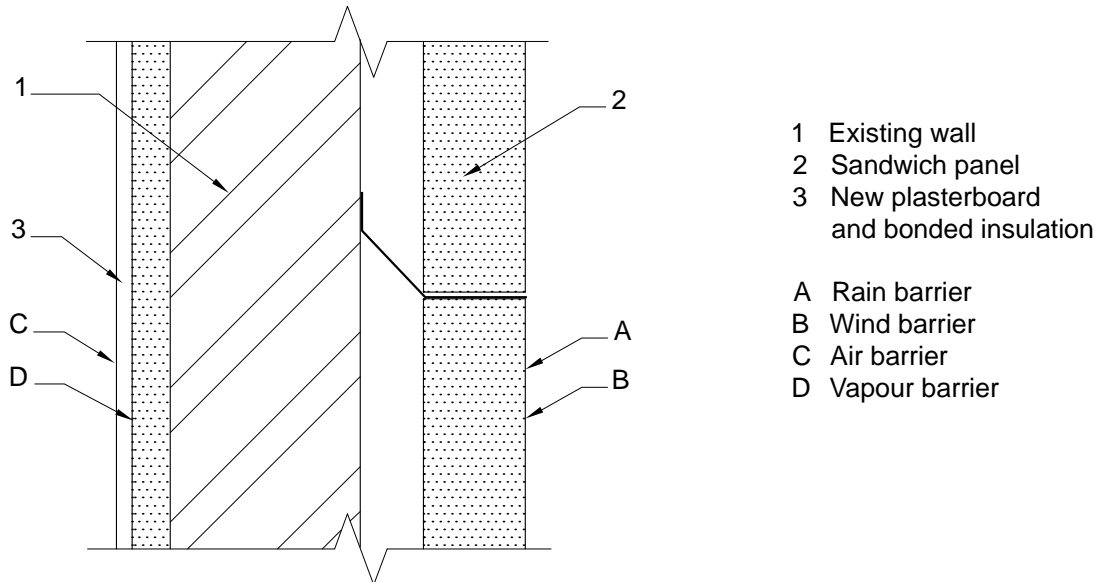

Type 5: Drained unventilated sandwich panel and internal insulation

Scale 1:5

## 2 Roof constructions using metallic or cement-based cladding

In enclosures using existing metallic or cement-based roofing, the existing roofing is generally of poor quality and air leakage can occur at joints, overlaps, and at roof lights. In renovation, a new sub-frame is attached directly through to the purlins below. The sub-frame supports the new roofing and can be designed to span between the main structural frames.

Various forms of over-roofing may be considered:

Type 1: Built-up roof with sub-frame and insulation. In this system, the sub-frame supports the new roof sheeting, and insulation is placed in the space between the new and existing roofing. The vapour barrier must be placed on or below the existing roof, or possibly between horizontal layers of insulation. It also acts as an air barrier.

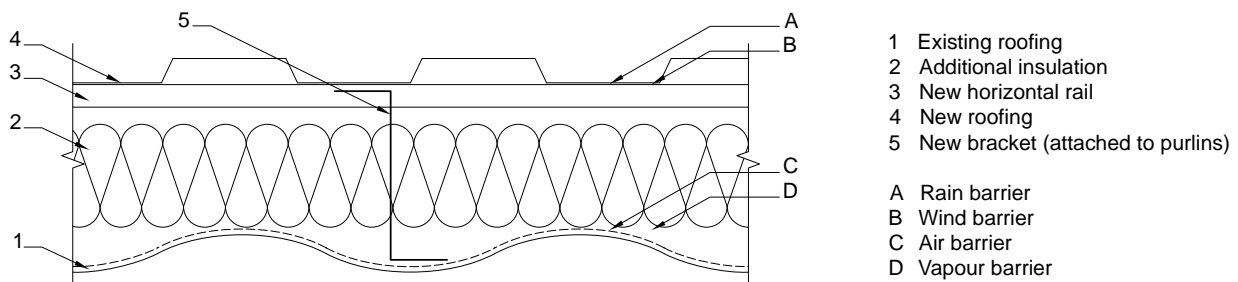

Type 1: Built-up roof with sub-frame and insulation

Scale 1:3.75

Type 2: Built-up roof with additional insulation placed above and below the existing roof. In this system, supplementary insulation is placed below the existing roofing, in which case the vapour barrier and air barrier may be installed as part of this additional layer.

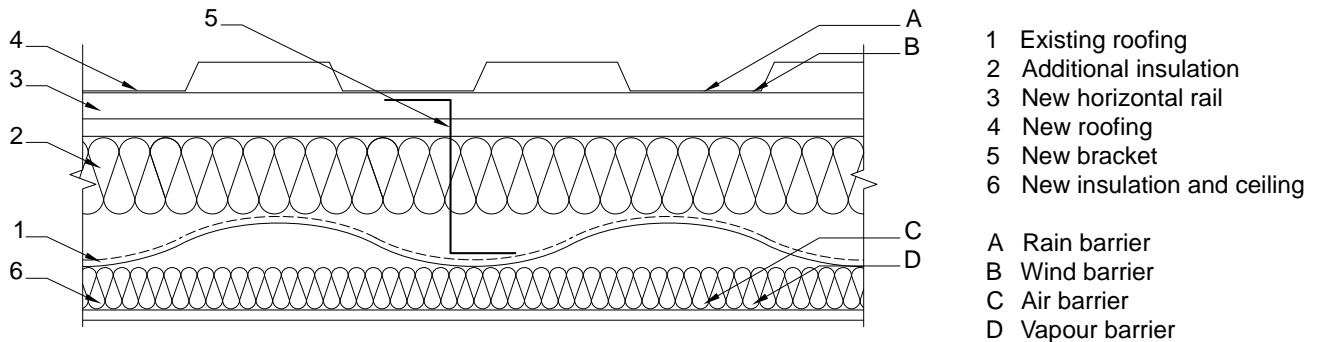

Type 2: Built-up roof with sub-frame and suspended ceiling

Scale 1:3.75

Type 3: Composite panels (or sandwich panels) with steel sub-frame. Composite panels can be designed to span further than conventional sheeting and can be supported either by a sub-frame located on every purlin or at multiples of the purlin centres. It is also possible to span the sub-frame between the main structural frames. The composite panels are effectively face-sealed and act as both a vapour barrier and air-barrier. However, this means that the details at the ridge and eaves and at roof lights must be sealed.

### 3 Wall constructions using metallic or cement-based cladding

Wall constructions using metallic or cement-based cladding may be treated in the same way as for similar roof constructions. However, walls often use horizontally spanning cassette panels that support the existing vertically orientated sheeting. In this case, the cassette panels are retained and new insulation is placed externally. There are two generic forms of construction:

Type 1: Cassette panels with additional insulation, thermal breaks and new sheeting. In this system, thermal breaks in the form of plastic blocks or timber battens are attached to the outstands of the cassettes and new insulation is placed between them. The cassettes act as a partial but unreliable vapour and air barrier. Therefore, it is necessary to introduce a continuous vapour barrier internally to provide these functions.

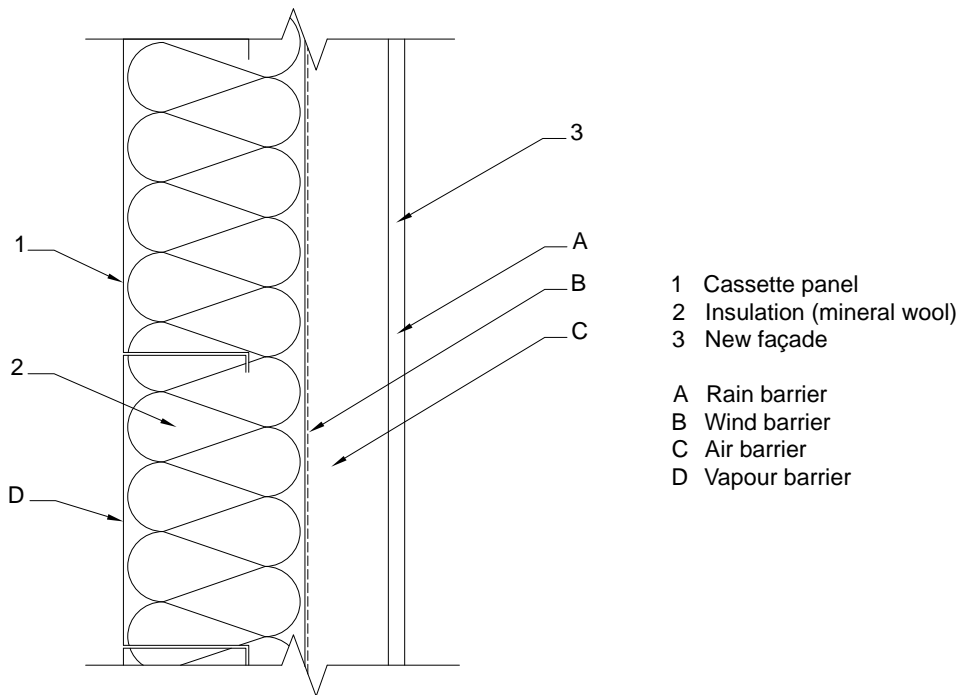

Type: Cassette wall and drained and ventilated cladding

Scale 1:5

**Type 2: Cassette panels with new composite panels.**

In this system, composite panels may be orientated horizontally or vertically and attached to the cassettes with or without additional insulation. The composite panels are designed to be face sealed.

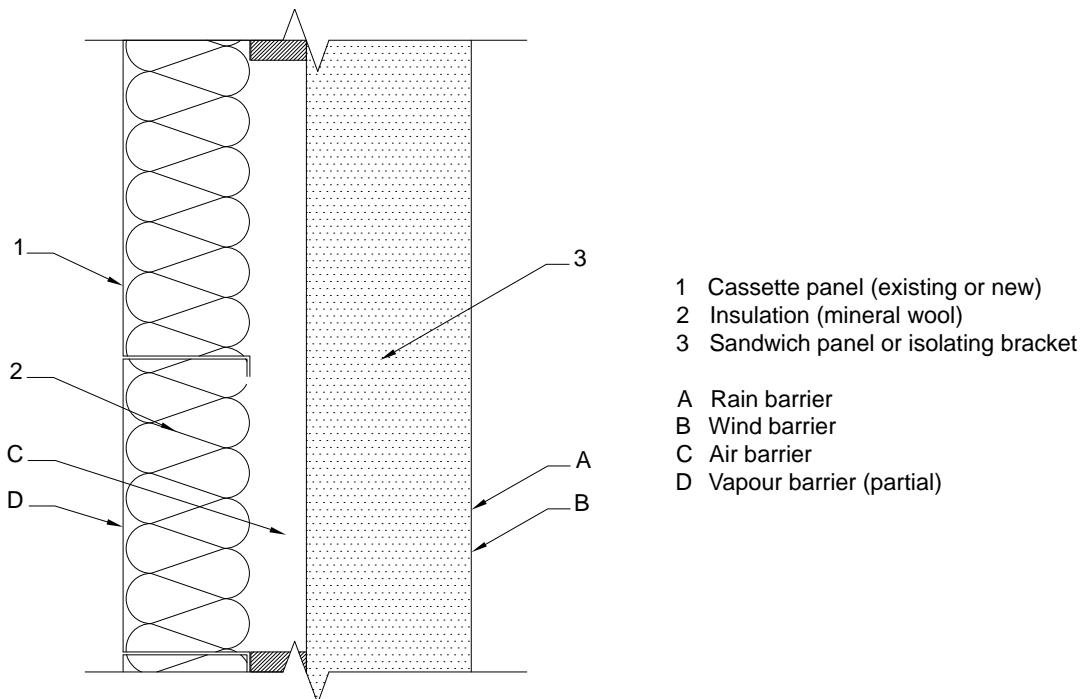

Type: Cassette wall and sandwich panel

Scale 1:5